

Installation Guide and Safety Manual

Soundproofing Acoustic Barrier



Soundproofing Barrier is a specially developed mass layer product offering industry-leading acoustic transmission loss combined with great damping properties. It is available in 1lb/sqft to 2lbs/sqft densities with STC ratings up to 32. It is a simple to install, highly cost-effective noise blocking material.

SPECIFICATIONS

STC. 22 to 32
Weight5lb, 1lb, 2lb
Temp Range-40 to 200° F
FlammabilityPasses

REQUIRED MATERIALS

Fasteners:

- 1.25" Staples and caps, with power cap stapler (Crossfire, Bostich, other)
- Roofing Buttonkaps, at least 1" (ring shank nail with plastic cap)
- 1.5" Coarse thread drywall screws, with fender washers

Tools:

- Drill or screw gun with mechanical fasteners
- 2" Vinyl or Foil Seam Tape
- Tape Measure
- Box Cutter
- 4' Straight Edge (T-Square or Level)

ACCESSORIES

- Sound Isolation Clips
- Vinyl Seam Tape
- QuietClips
- Foil Seam Tape
- Acoustical Caulk
- Sealtight Putty Pads



Soundproofing Acoustic Barrier is available in an UL approved version

UL approved in over 100 wall, floor, ceiling assemblies; U300, U400, V400, L500 series.

- Product must be stamped UL Classified. Do not accept as UL Classified if not stamped.

Copyright 2010
West Coast Sound Solutions
Soundproofing Los Angeles
No part of this document may be reproduced, in whole or in part, without the specific written permission of West Coast Sound Solutions
Soundproofing Los Angeles

WALL INSTALLATION GUIDE

- Soundproof Barrier can be used in several ways to provide a measurable improvement. The product is effective over existing walls and as the first layer on the studs with drywall attached over.
- Use fiberglass insulation at least ½ cavity depth.
- Cut material off rolls only as needed.
- Vertical seams will occur either on face of stud tightly butted, or in stud cavities (overlap by 2" and tape at least twice).
- Installation will be a two person job for walls, 3 people for ceilings.
- Ladders with paint can-shelf or scaffolding are required to support roll of material while fastening.
- Every electrical box, switch box or other penetration.



Measure the height of the wall



Cut Barrier to the appropriate length.

Installing Soundproof Barrier To Walls

1. Soundproof barrier will be fastened to the studs vertically. Complete coverage is required, top, bottom and vertical seams must be sealed with vinyl or foil tape.
2. Before starting, decide how vertical seams will be handled; either on the face of studs, or in stud cavities.
3. After measuring the height of the wall, cut the soundproof barrier to the appropriate length to cover the area from the top of the top-plate to the bottom of bottom plate.
4. Re-roll each section and place on the top of ladder or scaffolding. With two people, unroll 2 feet of the barrier so the barrier reaches the top of the wall. Making sure the barrier is square to the wall and flat, attach 5 fasteners along the top plate.

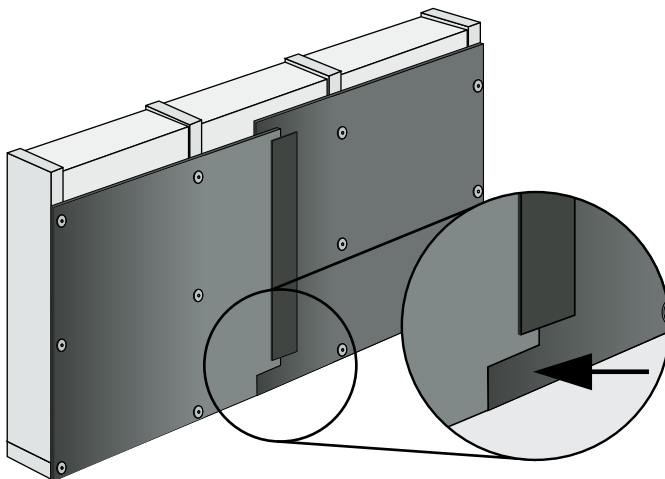

Above is an example of a vertical seam inside the stud cavity. Use foil or vinyl tape to seal each seam. Notch one side of the soundproof barrier over the top plate and the late, so only one layer of barrier is over the wood. This will allow the drywall to lay flat across the whole wall.

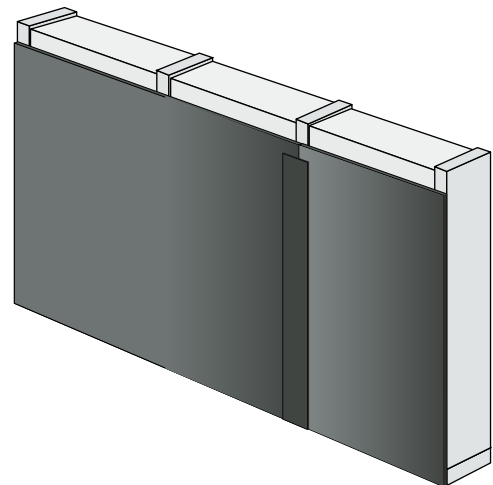

Above is an example of a vertical seam on the face of studs. Tape all seams and stagger the Buttonkaps along seam to allow the finished drywall to lay flat.

- Carefully roll the Soundproof Barrier down the wall, attaching it every 24" to all studs.
- Make 5 attachments at the bottom of the wall.
- Make box cutouts in barrier as they occur. Do not wait until the room is finished. For better performance, use Sealtight Putty Pads around electrical knock-outs.

Note: Do not try to support the weight of the roll while fastening; it should be supported by ladder or scaffolding.

- Check all fasteners to make sure they are flush to the wall, recheck all seams and cutouts for a tight fit.
- Proceed to next section until room is finished.
- Tape all vertical seams twice with foil or vinyl tape.
- When installing drywall, make sure to leave a 1/4" gap around the perimeter to be filled with acoustical caulk. Also be sure to seal around every electrical box cutout.

Note: It is very important to avoid a rigid connection at the perimeter of the soundproofed wall/ceiling when intersecting with a non soundproofed surface such as floor, other wall, or the ceiling.



Fastener the barrier in 5 spot at top of roll.



Tape vertical seams with foil or vinyl tape.

Ceiling Installation

Note: Button cap stapler or nailer is required.

- Install Soundproof Barrier perpendicular to the floor joist or framing.
- Cut product into usable sections and roll it up.
- Attach product to first floor joist at the wall with 5 fasteners.
- Unroll the product as needed to cover the next joist, and pull tight (this can be accomplished by holding the roll up into the joist cavity) attach again with 5 fasteners. Continue to the end of the roll.
- Tape all seams in the vinyl with foil seam tape to insure a tight fit everywhere. Seal any penetrations with SilenSeal Acoustical Sealant.
- Proceed by installing drywall or Sound Isolation Clips.

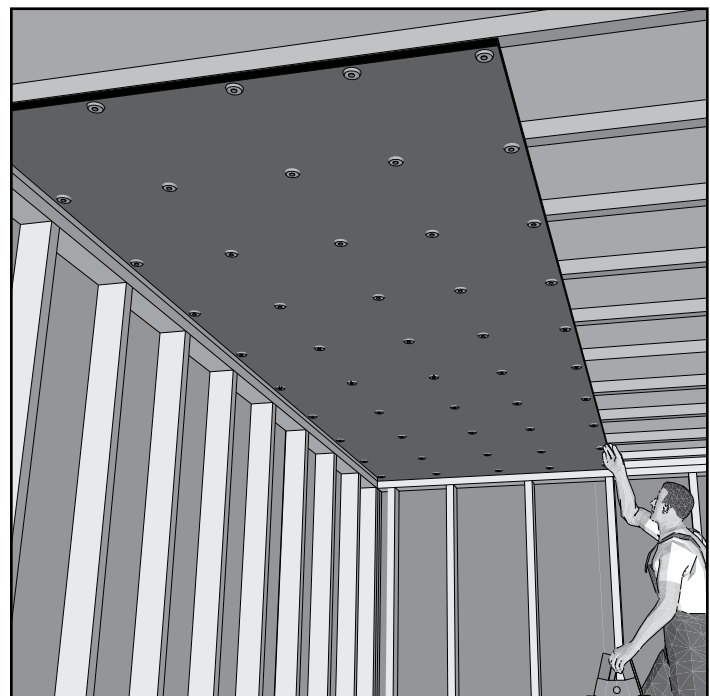

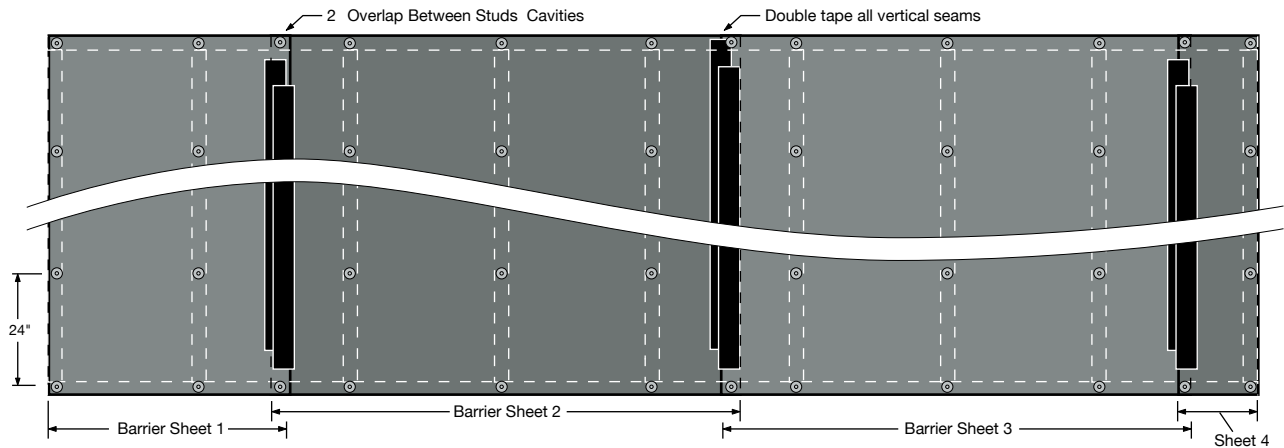
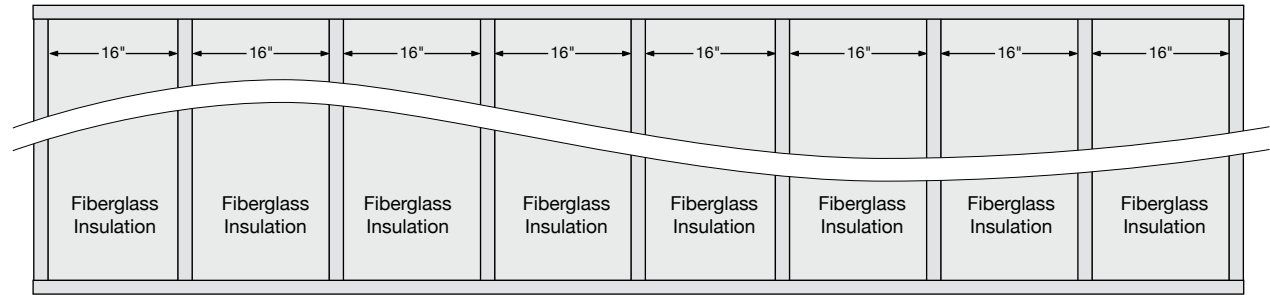

After measuring and cutting the barrier to desired length on the floor, re-roll and place it on a ladder or scaffolding near the ceiling. Unroll the barrier until flush with the ceiling and square to the wall. Attach the barrier to top plate in 5 locations. Continue nailing the barrier every 24 inches on every stud. Attach the bottom of the barrier in 5 locations.

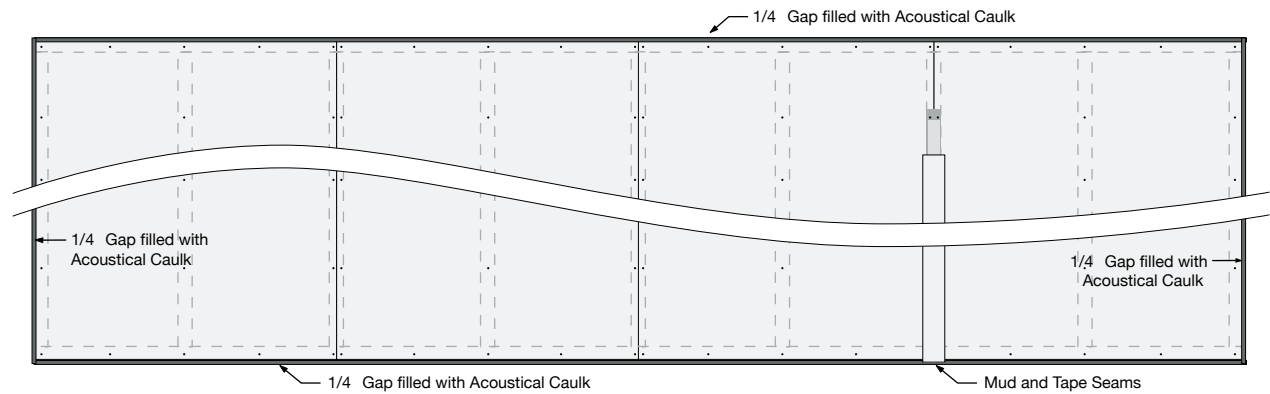

Attach drywall directly to the studs with standard drywall screws following local building codes. Leave a 1/4" gap around the perimeter of wall to be filled with acoustical caulk. Caulk the entire perimeter of the wall as well as any electrical cutouts with acoustical caulk.

Warranty: Because of the many installation variables beyond our control, we shall not be liable for incidental and consequential damages, directly or indirectly sustained, nor for any loss caused by application of these goods not in accordance with current printed instructions or for other than the intended use. Our liability is expressly limited to replacement of defective goods. Any claims shall be deemed waived unless made in writing to us within thirty (30) days from the date it was or reasonably should have been discovered.

Disclaimer: These application notes represent the accepted procedures for successful installation of Green Glue. These suggestions may be followed, modified, or rejected by the owner, engineer, contractor, and/or their respective representative(s) since they, not Sound Isolation Company, are responsible for planning and executing procedures appropriate to a specific application. Sound Isolation Company reserves the right to alter these suggestions and encourages contact with the factory or its representatives to review any possible modification to these application notes prior to commencing installation. It is the responsibility of the owner, engineer, contractor, and/or their respective representative(s) to ensure that installation meets all applicable Building Codes. There is no performance warranty expressed or implied for any particular project or installation.

Returns: A 15% restocking fee will apply to all returned items. Returns must be made within 60 days of customer's receipt of original shipment. Returns after 60 days are not allowed.